



# *hyper*DENT<sup>®</sup>

## THE ART OF DENTAL ENGINEERING



**FOLLOW-ME!**  
TECHNOLOGY GROUP

# hyperDENT®: At the forefront of dental engineering.

Our motto is to work hand in hand with our customers and partners, and this is key as to how we lead the way in the development of innovative technologies.

**FOLLOW-ME! Technology Group** develops and distributes an industry leading dental CAM software, *hyperDENT*®. Due to its' modular product structure, the software can be utilized with a myriad of milling machines. *hyperDENT*® generates intricate and stable toolpaths which coupled with advanced safety mechanisms, offers both a stable and intuitive production process to end users. FOLLOW-ME! Technology Group is headquartered in Munich, Germany, and has offices in Berlin, Italy, Spain, Korea, Singapore, China, Japan and the United States of America.

We at FOLLOW-ME! incorporate the spirit of innovation into our software that is a manifestation of the Art of Dental Engineering. This is our core, and it pushes us to strive to remain at the forefront of technology by continuing to develop and deliver performance based products that encapsulate industry leading milling algorithms. Our technology is backed by a "five star" customer support on a worldwide basis.

This has afforded us the ability to expand three-fold in recent years, and we now have a worldwide network with offices in three continents. Our global presence benefits our customers by giving them access to leading technologies and leading support, by industry leading minds. Connecting these key elements, our customers can leverage our strength and remain competitive in the global market.

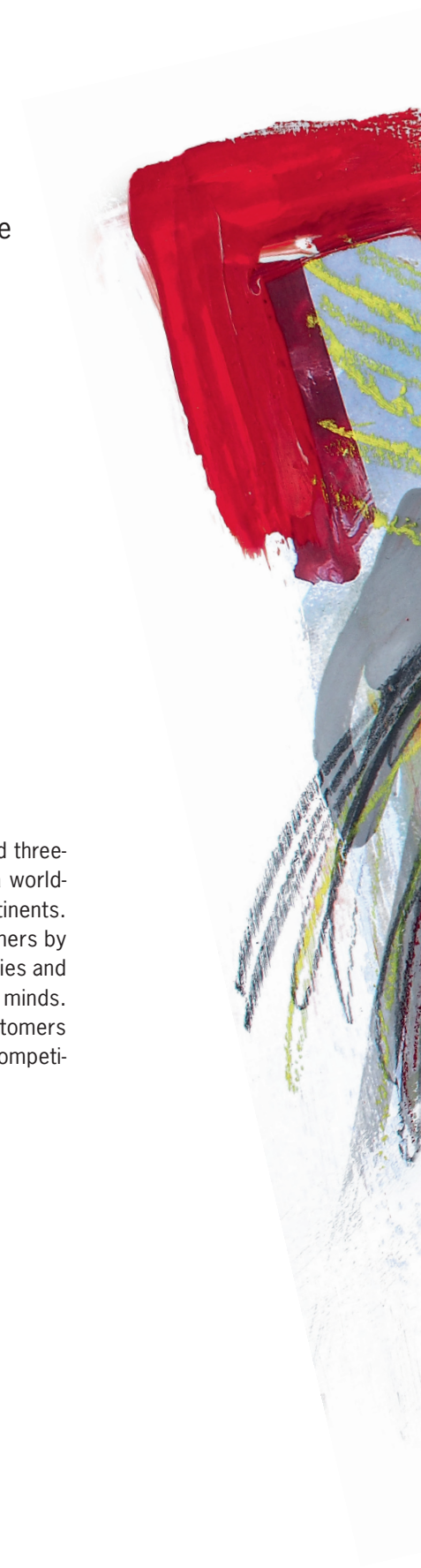







## hyperDENT®: Success through cooperation.

As digital technology in the dental market continues to develop, a broad network of partners in the dental industry is an indispensable asset when it comes to meeting increasing customer demands.

**Quality counts:** Dental machine tool companies often pre-select a proven CAM software with which they bundle their machines before selling to their customers. They do this in order to ensure their customers will achieve the best results with their machines in the production process. *hyperDENT*® is the most widely selected bundled CAM software, and this is proven by our strong partner network.

**Flexibility counts:** As the path to digitization in the dental industry expands, CAD/CAM system integrators are on the increase. These integrators offer their customers the opportunity to select their own individualized process chain, including their choice of hardware components e.g., scanners or milling machines. The CAM software however, is usually predetermined. Apart from performance and quality, integrators that choose *hyperDENT*® have increased flexibility to meet their customers' needs. This is primarily due to the fact that machining templates can be individually produced with the internal Template Generator.



**Global presence counts:** With many dental components being sourced and supplied from abroad, the supply chain in dental technology has reached a global scale. Whether these components are sourced from America, Asia, or Europe, integration is essential for a successful digital workflow. *hyperDENT*® is available worldwide and distributed by a strong international partner network. This ensures that new products from each region can be integrated with our CAM software.



# hyperDENT®: A product line for each market segment.

hyperDENT® targets different dental market segments from small dental laboratories to milling centers. Customers can choose which hyperDENT® version best suits their business needs: **hyperDENT® Classic** or **hyperDENT® Compact**. Depending on individual needs, customers can also add on software from the hyperDENT® Options range.

## hyperDENT® CLASSIC

FOLLOW-ME!'s flagship product allows for the production of ALL your digitally designed dental applications. Its' robust features and unique customization options give labs and milling centers complete control of their manufacturing needs. Containing all that is included in Compact, hyperDENT® Classic is a step up and suitable for large-sized labs. Features such as Multipart Roughing contribute to workflow efficiency by reducing material waste, increasing tool life and decreasing milling times. Another handy feature is User Defined Areas, which allows technicians to manually select and define a specific area of a dental object which they feel may require special attention. Drastic time reductions are also achievable with the Multiple Start feature. This provides the option to work and calculate on more than one project – leaving the operator free to spend time on other issues.

## hyperDENT® COMPACT

As the demand for in-house milling production began to rise, a leaner, simpler to use edition was created; hyperDENT® Compact. This CAM software unlocks the true potential of common bench-top-type mills, while staying sensitive to the lower-cost nature of this machine category. All of the key advantages of a fast, safe, efficient and precise workflow process that hyperDENT® is renowned for, is maintained. Even though this edition is lean, it contains all of the core requirements that any lab would need. With its user friendly interface, extensive training is not required and can therefore be used by technicians without previous CAM experience.

## hyperDENT® OPTIONS

Staying up-to-date with CAM technology can be difficult without a product that gives its users flexibility. The hyperDENT® Options category allows for specific modules to be added in order to compliment or enhance current software. It can assist users to manufacture new types of indications, or customize their current capabilities and solutions.

The **hyperDENT® Grinding Module** adds special toolpaths for the production of glass ceramics. These toolpaths specifically address the complications of grinding with water-cooled diamond cutters, so that the highest quality and most efficient production of these materials can be achieved.

The **hyperDENT® Denture Module** is a fully automated CAM process that cuts out more than half of the steps required in the traditional full denture process. It is the first full denture capable software system that utilizes automated toolpaths and parameter calculations. This includes both the lower and upper jaw components, which allows for easy digital handling and is particularly beneficial for novice users.

The **hyperDENT® Template Generator Module** is for advanced CAM users who need to create individualized machining templates in order to work completely independently and without restraint with new tools, materials and restorations. In conjunction with this module, *hyperDENT®* possesses a unique and flexible selling point in the market like no other, as other CAM suppliers often create the machining templates themselves, to then sell them on to their customer.

The **hyperDENT® Implant Module** enables the milling of individual abutments, implant bars, and screw-retained bridges. With this module, these somewhat complex restorations can be milled easily with high quality results. This is also because the *hyperDENT®* library of interface geometries disregards the inconsistency of implant interface geometries from different CAD systems and scan adapter libraries, by replacing the geometry with a perfectly fitting alternative.

The **hyperDENT® Hybrid Module** utilizes additive and subtractive production technology with the incorporation of both laser sintering and milling strategies. This new technology is particularly advantageous for the mass production of dental indications which require superior surface quality in particular areas, e.g. implant based indications.

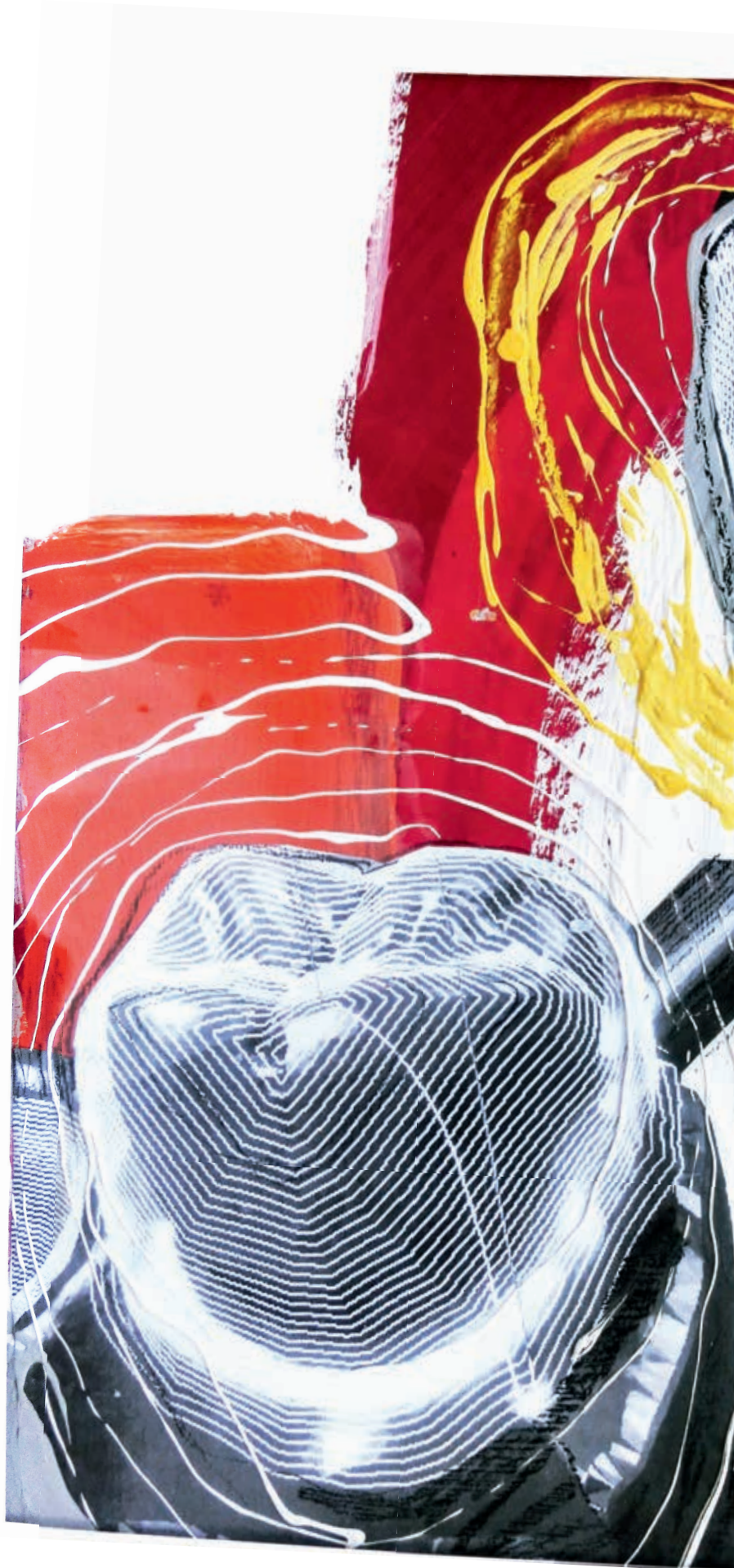

# hyperDENT® Highlight: Inhouse production made easy with hyperDENT® Practicelab.

hyperDENT®Practicelab is one of the easiest to use CAM software products on the market and was specifically designed for glass ceramic indications or indications from soft material, where more complex milling strategies are not required.

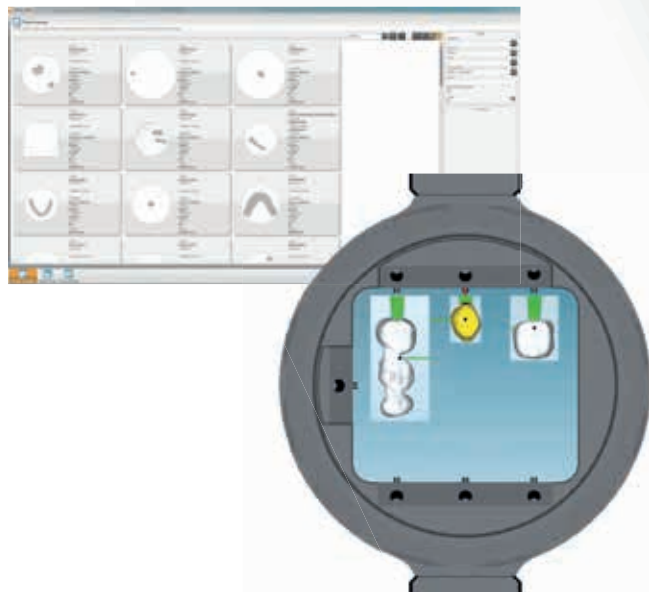
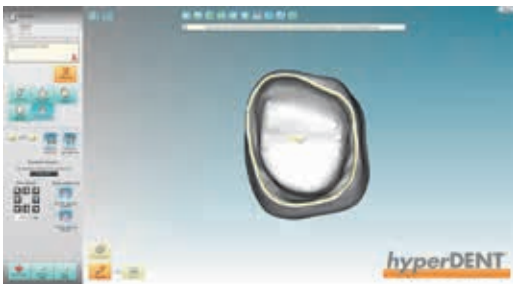

**hyperDENT® Practicelab** has a significantly simplified interface so the computerized steps are familiar from the get-go. The all-new touch screen technology that is incorporated eliminates the need for a mouse, allowing for a neat and tangle free workspace to compliment any dental lab. So much automation has been packed in to this slim and trimmed down version of hyperDENT® that it is a perfect solution for novice users. The workstep wizard guides users through the complete workflow process and provides simple operational commands, which means that no technical jargon is required in order to navigate menus and functionalities. The Multi-part Fixture functionality allows for more than one raw part to be loaded and milled at the same time.

Another introduction to the hyperDENT® Practicelab is the Machine Connector feature (which can be activated when the machine-tool company provides a corresponding API). This allows for the NC file to be sent automatically to the milling machine once it is calculated, which saves time in the production-process. Additionally, an integrated Tool Life Tracker informs the user on the spot about the status of tools and when a tool replacement needs to be done.



PrepLineInsert(Dir.png) Windows-Einstellungen  
E-Mail Brennen Öffnen

Check and modify settings before to using camera and software, and the camera or software is not used again.

Prep 0815  
1525512  
Preparationsgröße(n) fehlen  
[red X icon]

Part type  
Main milling direction  
Pilot direction  
Drilling direction  
Pre-cut direction

1/1  
Adapt to insert dir.  
Adapt to tool insert dir.

Insertion direction  
Set insertion direction from current view  
From view

Fine-adjust  
[directional arrows]  
100%

Show undercut  
Include opposite direction  
Exclude opposite direction

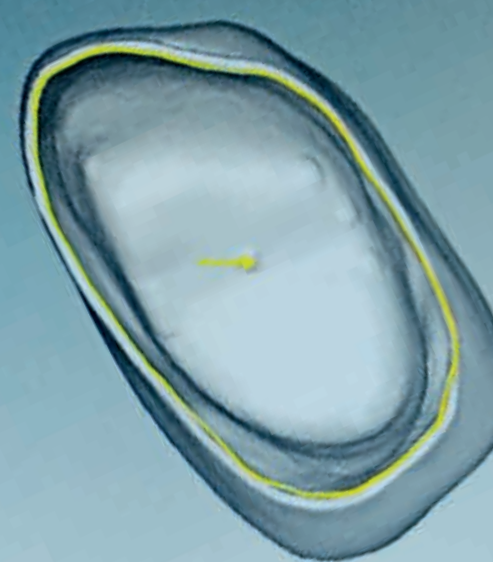

## *hyperDENT*<sup>®</sup>: No restrictions on restorations or materials.

Sophisticated CAM software must be able to cover a broad spectrum of restorations and materials, so that the user can respond effectively to current and future market requirements. *hyperDENT*<sup>®</sup> does not just develop with the market – it is often a step ahead, so it's not rare for innovations to be available in *hyperDENT*<sup>®</sup> before anywhere else.



High-quality classic and innovative restorations, can be created with *hyperDENT*<sup>®</sup>, meaning there are no limits to the standard repertoire (crowns, bridges, inlays/onlays, etc.) of the dental technician. Even with innovative restorations such as individual abutments or bars for dental implants, *hyperDENT*<sup>®</sup> can demonstrate its overwhelming superiority. Full dentures and bite splints are other examples of restorations that can be machined with *hyperDENT*<sup>®</sup>.

A wide variety of materials can be machined with *hyperDENT*<sup>®</sup>. Whether working with soft materials such as zirconium oxide, PMMA or wax, or hard materials such as cobalt chromium or titanium, *hyperDENT*<sup>®</sup> always delivers first-class results. The more challenging the material properties, the more intensively the strengths of *hyperDENT*<sup>®</sup> are called upon, which is how our own patented grinding strategies for glass ceramics were developed.





## *hyperDENT*® Highlight: Efficient milling of prefabricated abutments.

Prefabricated abutment milling is on the rise as it allows for the processing of implant abutments from any machine with titanium milling capabilities.

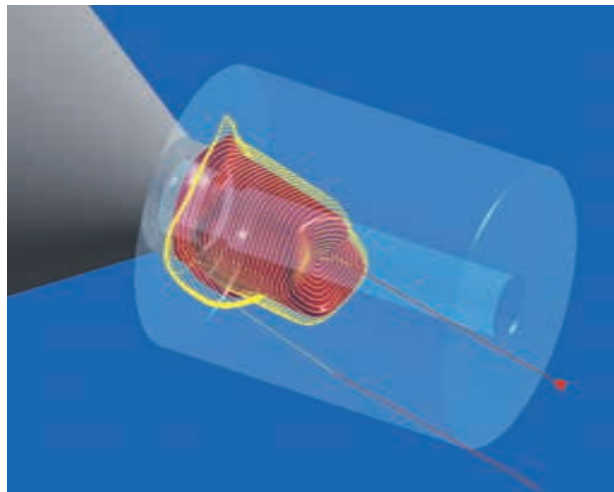
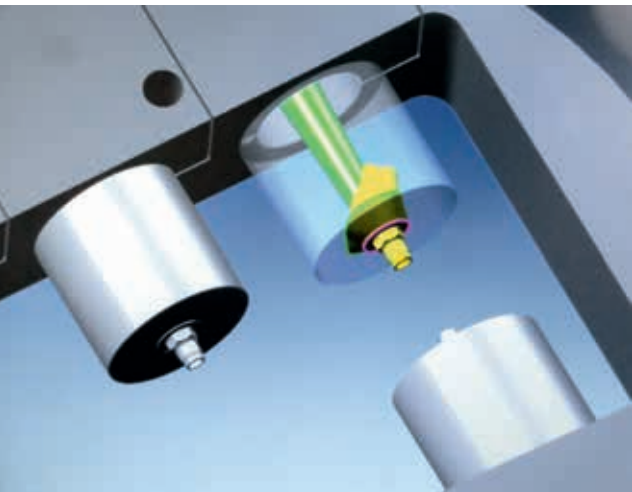

In the case of prefabricated abutments, the implant interface and screw channel have already been pre-milled, therefore, the lab or milling center only needs to finish the emergence, shoulder, and abutment body. This translates to faster manufacturing times, as the most intricate process has been completed. Additionally, *hyperDENT*® allows for prefabricated abutments to be milled using either multipart or single fixtures, providing even more flexibility and freedom of choice.

Moreover, the Multipart Fixture functionality within *hyperDENT*® allows for more than one blank to be loaded and milled at the same time. On top of this, there is the benefit of an optimized calculation

of tool changes across all of the blanks. This combination equates to far less preparation time for the setting up of more than one project, as well as significantly faster milling times.

Without prefabricated abutment milling options, laboratories would otherwise need to spend on outsourcing, or invest in expensive higher-end equipment to bring the production of custom titanium abutments in-house.



## *hyperDENT*<sup>®</sup> Highlight: Implant Module – for the production of complex implant structures.

Although screw retained implant-based indications are one of the largest areas of growth in the dental market, their production is highly demanding of the technology used, due to the extreme levels of precision that must be reached. The *hyperDENT*<sup>®</sup> Implant Module is perfectly meeting these requirements.

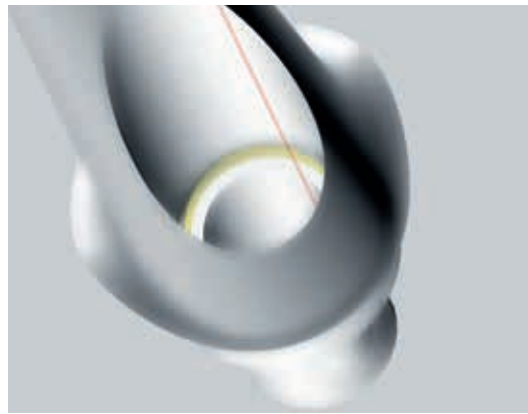
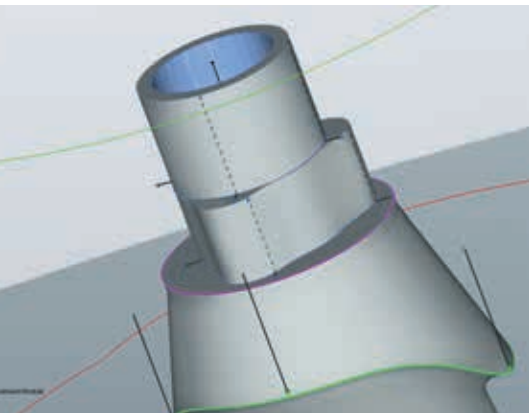

The ***hyperDENT*<sup>®</sup> Implant Module** provides a range of intelligent functions for ensuring the necessary precision of produced parts. With this, the screw fit for the screw channel machining can be milled separately. Additionally, the correct tool for drilling the screw channel can be allocated by the automatic diameter detection. Furthermore, the interface geometry can be produced in a section-specific, tool-specific or geometry-specific manner, making this yet another aspect in which the highest level of precision is ensured.

Due to the library of millable interface geometries for the most common implant systems, the *hyperDENT*<sup>®</sup> Implant Module can also be linked with a corresponding CAD dummy geometry library. An automated geometry exchange mechanism ensures that highly precise parts can be produced in spite of any inconsistencies in the upstream systems.

Additionally, production of angulated screw channels are possible with the *hyperDENT*<sup>®</sup> Implant Module. The revolutionary feature allows the drilling of screw access holes on an angle of up to 30 degrees for any given prosthesis. This allows dentists to place implants in a more ideal position than was previously possible, as with the Angulated Screw Channel feature, a more accurate angulation can be milled, providing significantly greater flexibility. Using existing *hyperDENT*<sup>®</sup> software and milling equipment, dental labs and milling centers can now offer similar high-end features on their implant based restorations just as any implant manufacturer.





## hyperDENT® Highlight: Digitalizing denture production with the Denture Module.

Creating full dentures was once a tedious and time consuming analogue process. However, this process is now a digital reality which translates to significantly less bench time for dental technicians.

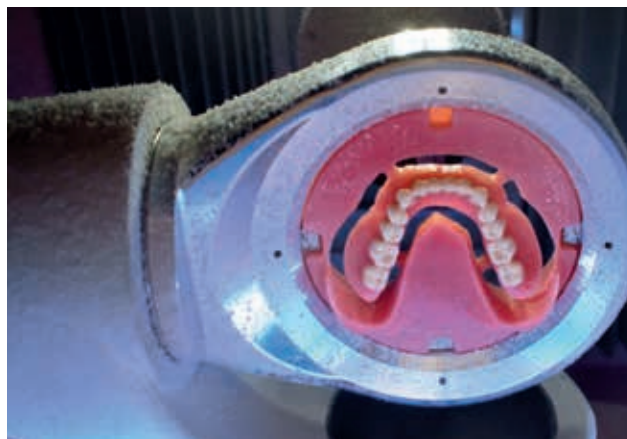

The only manual necessities required in the *hyperDENT*® full denture process after the digitization is complete, is the final characterization and polishing of the dentures. The ***hyperDENT*® Denture Module** is the first full denture capable software system that utilizes automated tool paths and parameter calculations found on any type of milling machine. This includes both the lower and upper jaw components, which allows for easy digital handling. Particularly beneficial for novice CAM software users, the Denture Module requires a shorter learning curve when integrating this new technology.

Two various methods can be adopted with the Denture Module. The first of which utilizes pre-fabricated denture blanks, where the only part remaining to be milled is the patient specific residual ridge and pallet region. The second available milling option utilizes PMMA blanks, whereby the denture base is milled to include tooth pockets, which prosthetic teeth are the later inserted into.

As a standalone product, the *hyperDENT*® Denture Module does not require for a laboratory to invest in a new CAM software package. This module has the capability to function independently from an operators' core CAM workflow – saving the unnecessary hassle of new software integration.







## *hyperDENT*® Highlight: The Grinding Module for effective grinding of glass ceramic.

Glass ceramic and other composite materials are the future of dental technology, as they offer some considerable advantages over conventional materials in terms of aesthetics and durability. However, these materials are often considerably more demanding to work with. This is therefore an area in which the performance of a CAM software is essential.

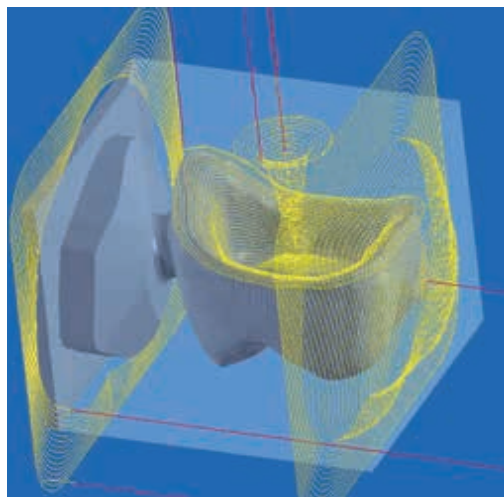

The machining of glass ceramic with traditional milling strategies places a great amount of strain on the milling tools, which are costly to replace. Specific grinding strategies are therefore required if the tool-life is to be optimized.

*hyperDENT*® uses patented peeling strategies for the machining of glass ceramics, making use of the entire length of the tool and therefore working in a far more efficient manner than if classic milling strategies were used. These intelligent peeling strategies, additionally ensure optimum processing times and optimal results.

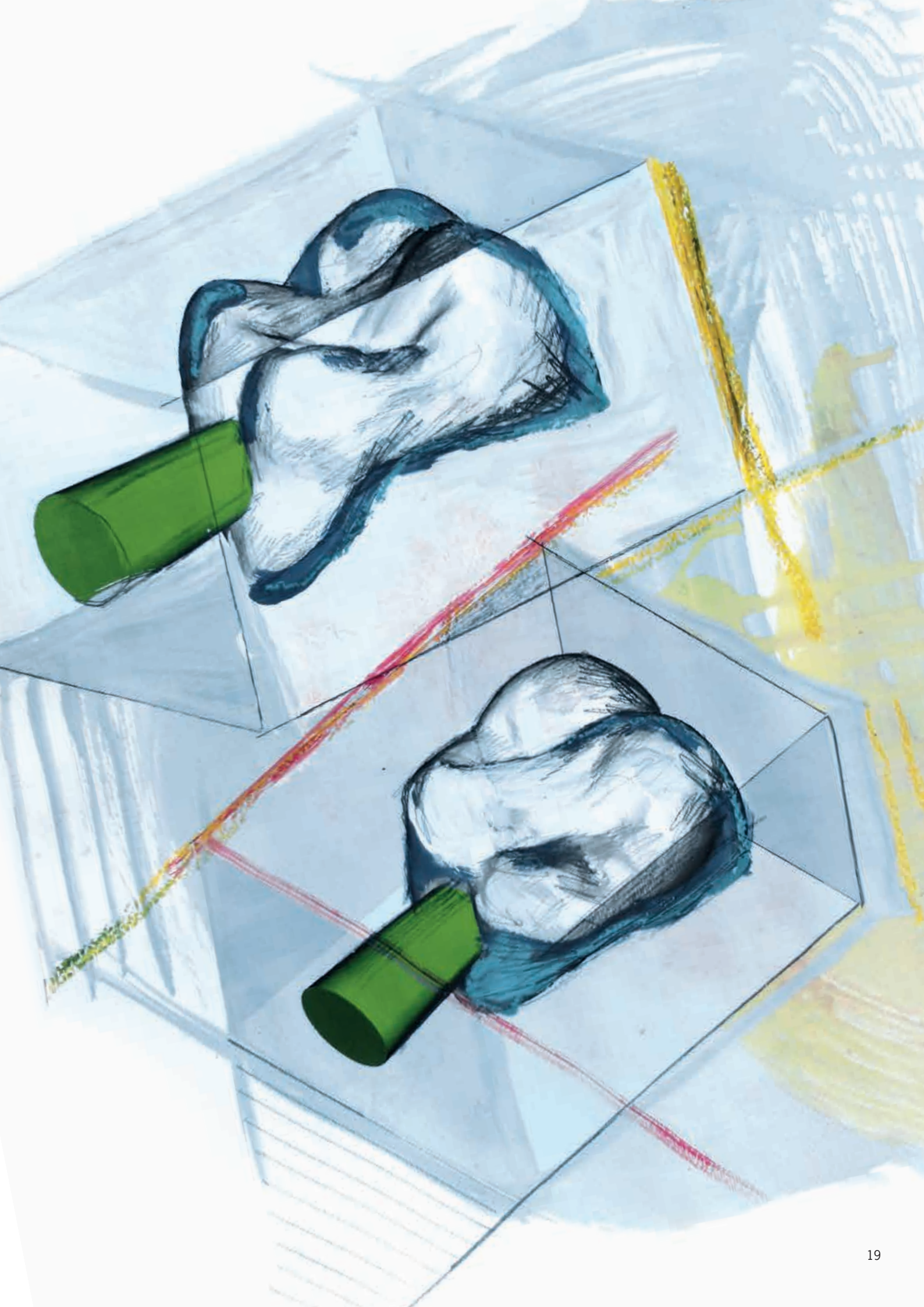



## *hyperDENT*<sup>®</sup>: Quick, simple, and reliable.

Intuitive operation, quick calculation and milling, combined with premium results, are performance indicators that customers should expect from a CAM software. No other CAM software has the functionalities that are built into *hyperDENT*<sup>®</sup> that allow all three of these performance indicators to be achieved, providing *hyperDENT*<sup>®</sup> users with a clear-cut advantage.

Ease of use or a high degree of automation in a CAM software is essential for operators, as they often only have little experience in CAM programming. *hyperDENT*<sup>®</sup> provides a series of functions that simplify the workflow process, as well as automation functions which relieve the user from many manual processes.

Application performance of a CAM software can be demonstrated by its calculation and milling times and secondly in its stability during the workflow process. The calculation times of *hyperDENT*<sup>®</sup> are faster than most due to the multicore support it possesses, which delivers

information directly to the processors' core. Secondly, *hyperDENT*<sup>®</sup>'s stability is due to its various and sophisticated collision controls, which prevent milling accidents from the get-go. The quality of the end result can be assessed by the fit and level of surface quality of the milled indication. Both of these factors are strongly influenced by the superiority of the underlying tool paths. *hyperDENT*<sup>®</sup> can draw on its own CAM kernel which has been derived from the world leading industrial kernel *hyperMILL*<sup>®</sup>. Therefore, parts milled with *hyperDENT*<sup>®</sup> stand out in superiority due to its industrial-like performance quality.









## *hyperDENT*® Highlight: Create individual machining templates with the *hyperDENT*® Template Generator Module.

*hyperDENT*® is the only CAM product that provides a full-sized Template Generator enabling customers to create their own milling strategies in a simple, straightforward manner. This allows our customers to operate independently and protect their milling knowledge, as the need to divulge milling strategies to a third party is not required.

It is essential to have the opportunity to react to customer requirements, but it is also very important to have the freedom to utilize different material or tool partners in the production process. However, if the machining template being used cannot be individually designed or adapted, then flexibility and freedom of choice is significantly restricted.

Users of the ***hyperDENT*® Template Generator Module** on the other hand, can conveniently select their machining strategies via a dialog box and set the parameters for the strategies needed to correspond to their requirements. This means that materials and tools are freely configurable, providing paramount flexibility.

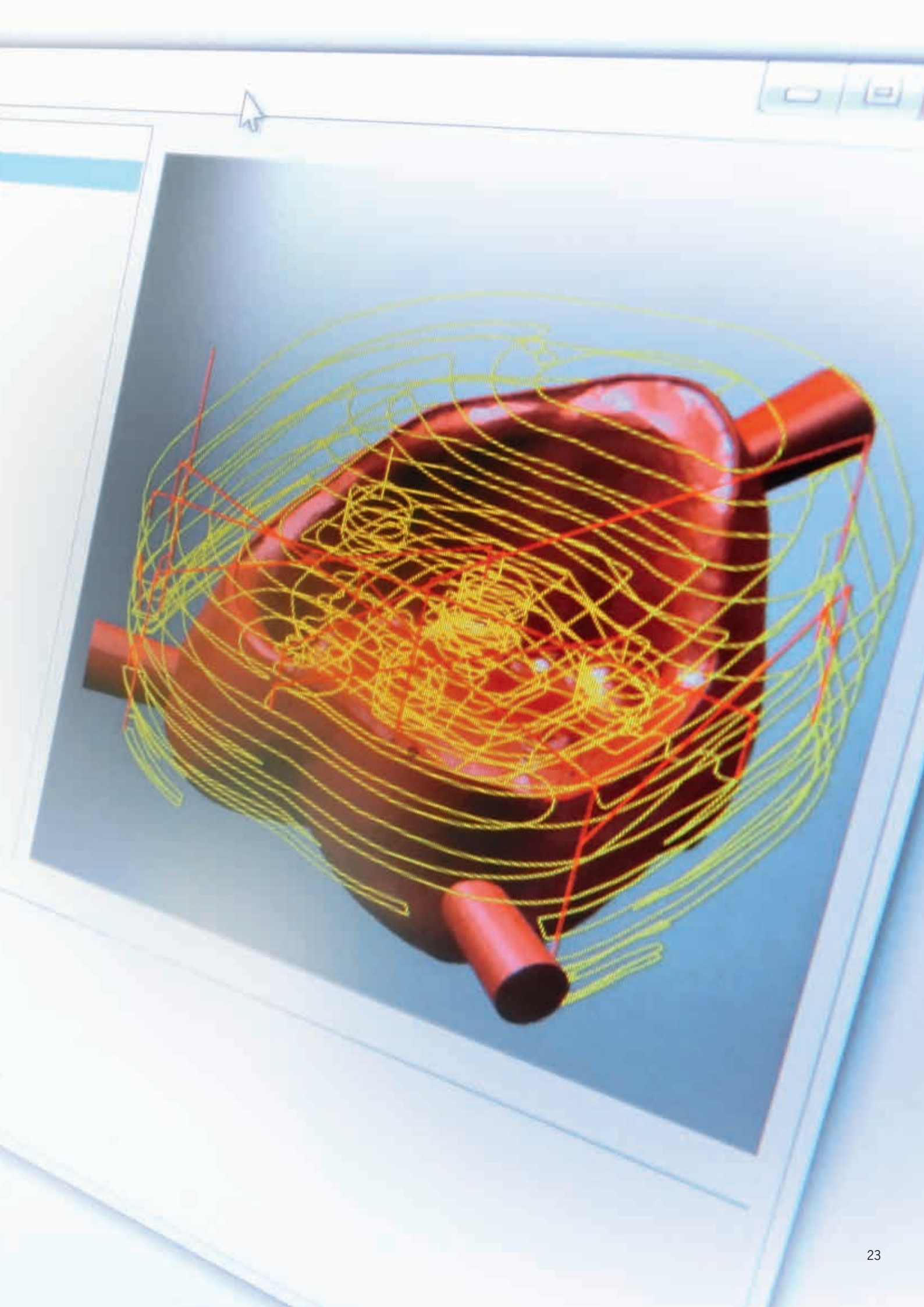



## *hyperDENT*<sup>®</sup> Highlight: Hybrid production (additive plus subtractive) with *hyperDENT*<sup>®</sup>.

The *hyperDENT*<sup>®</sup> Hybrid Module incorporates functionality that allows for a combination of laser sintering and milling in the dental workflow. The marrying of these two technologies provides the possibility to mass produce dental indications with superior surface quality while simultaneously maintaining a bare minimum of material wastage.

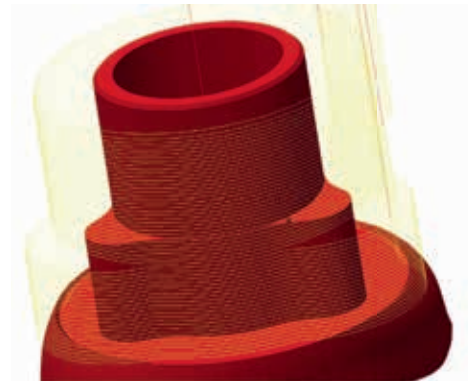
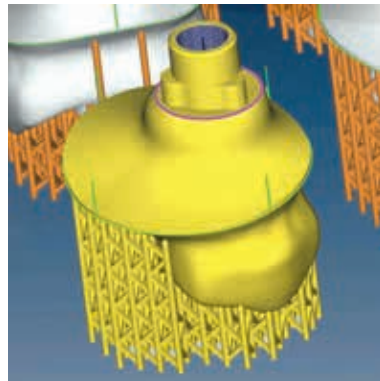

Special features of the new ***hyperDENT*<sup>®</sup> Hybrid Module** include:

Easy workflow: All-in-one CAM software which prepares the data for both laser sintering and milling production technologies.

Advanced user interface: offers all required functionalities for the additive manufacturing process.

Automatic reference geometries: created based on individual process requirements.

Autonesting: for optimal placement of dental restorations, taking the required space for the postmilling process into account.

Support structures: connectors which are sintered below the dental part and are automatically determined.

Partial mesh offset: allows for additional material to be sintered in a specified area where milling has been planned. The additional material can then be milled in the second stage of the production process.

Tagging: Each component that has been sintered and/or milled will be tagged. This allows for simple identification of each project/job number, eliminating a potentially time consuming identification process.





# The Art of Dental Engineering.

Dental engineers and artists typically share a similar approach to their work. They leave traditional methods and paradigms behind in their process of creativity, using inventive ways of thinking to create their masterpiece.

FOLLOW-ME! Technology similarly utilizes this creative approach in our corporate design. You will find pieces of our collection **“The Art of Dental Engineering”** incorporated in our exhibition booths and marketing materials. This is our approach of creating a unique brand positioning in the dental market. Just as the development process of *hyperDENT*® evolves, so too does the series The Art of Dental Engineering where unique pieces of art continue to be developed and evolve.

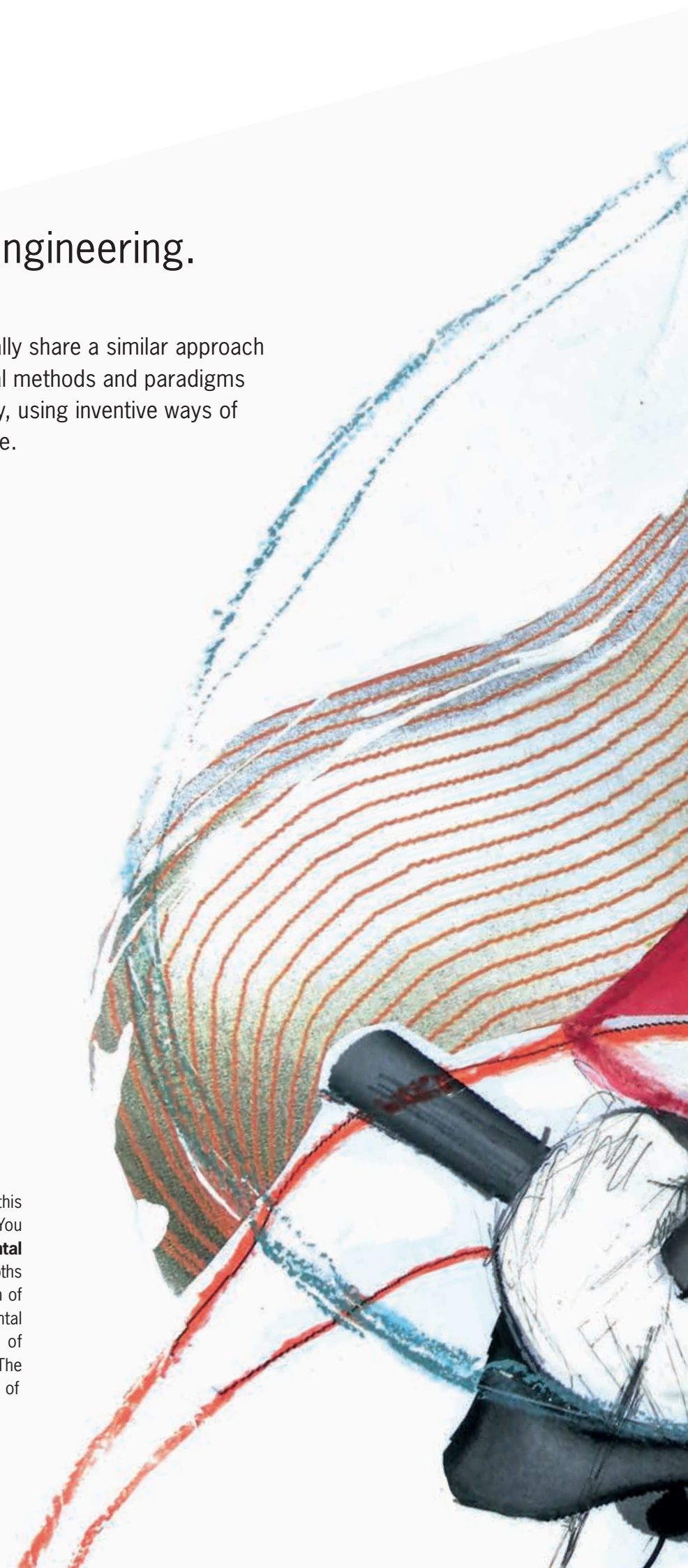







FOLLOW-ME! Technology GmbH  
Head Office  
Regerstraße 27  
81541 Munich, Germany  
Tel.: +49 89 45217060  
E-Mail: [info@follow-me-tech.com](mailto:info@follow-me-tech.com)

FOLLOW-ME! Technology China Co., Ltd.  
C1-18A, Kingkey Banner Square, Binhe Ave.,  
Xiasha, Futian District, Shenzhen,  
China, 518048  
Tel.: +86 755 2348 4146  
E-Mail: [info.cn@follow-me-tech.com](mailto:info.cn@follow-me-tech.com)

FOLLOW-ME! Technology GmbH  
Berlin Office  
Stresemannstraße 21  
10963 Berlin, Germany  
Tel.: +49 30 65835332  
E-Mail: [info@follow-me-tech.com](mailto:info@follow-me-tech.com)

FOLLOW-ME! Technology Korea Co., Ltd.  
#A-703, Xi-Tower, 401,  
Yangcheon-ro Gangseo-gu,  
Seoul, 07528, Korea  
Tel.: +82 2 2162 3707  
E-Mail: [info.kr@follow-me-tech.com](mailto:info.kr@follow-me-tech.com)

FOLLOW-ME! Technology South Europe Srl  
Italian Office  
Via Martiri di Belfiore 1  
20017 Rho-Milano, Italy  
Tel.: +39 02 9307814  
E-Mail: [info.see@follow-me-tech.com](mailto:info.see@follow-me-tech.com)

FOLLOW-ME! Technology Asia Pacific LLP  
4 Battery Road  
# 25-01 Bank of China Building  
Singapore 049908  
Tel.: +65 64384701  
E-Mail: [info.ap@follow-me-tech.com](mailto:info.ap@follow-me-tech.com)

FOLLOW-ME! Technology South Europe Srl  
Spanish Office  
Luis de Santangel 1A, 1, 6  
46612, Corbera (Valencia), Spain  
Tel.: +34 634 684 322  
E-Mail: [info.es@follow-me-tech.com](mailto:info.es@follow-me-tech.com)

FOLLOW-ME! Technology Japan Co., Ltd.  
7<sup>th</sup> floor, ASTEM Kyoto, 134 Chudoji Minamimachi  
Shimogyo-ku, Kyoto-City  
Kyoto, Japan 600-8813  
Tel.: +81 75 311 4630  
E-Mail: [info.jp@follow-me-tech.com](mailto:info.jp@follow-me-tech.com)

FOLLOW-ME! Technology North America Corp.  
3 Executive Park Drive, Suite 250  
Bedford, New Hampshire 03110, USA  
Tel.: +1 847 420-6542  
E-Mail: [info.na@follow-me-tech.com](mailto:info.na@follow-me-tech.com)

**[follow-me-tech.com](http://follow-me-tech.com)**